

ASSEMBLY INSTRUCTIONS

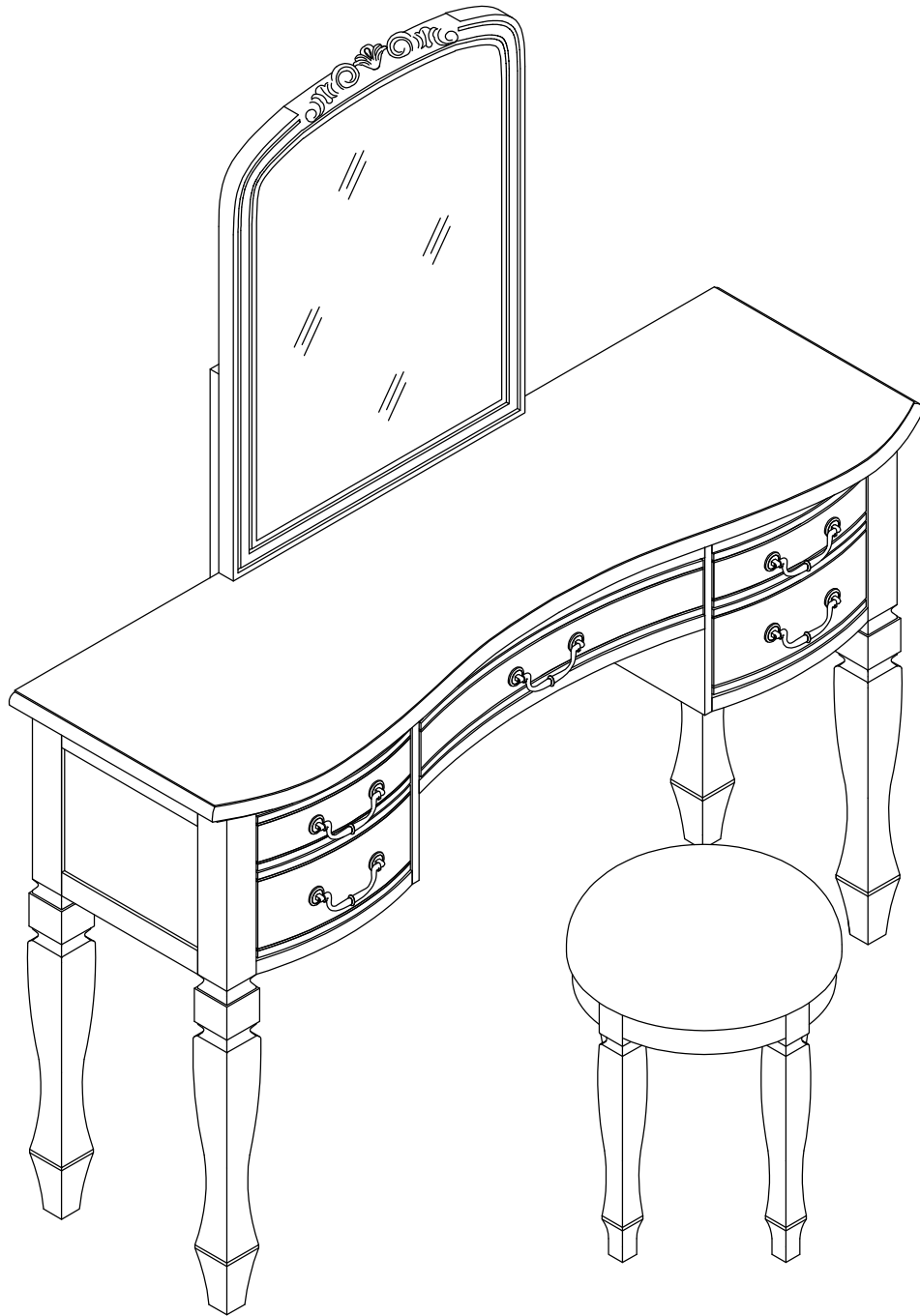

NOTE: 50% TIGHTEN BEFORE FIXING ALL BOLTS
N704P381405

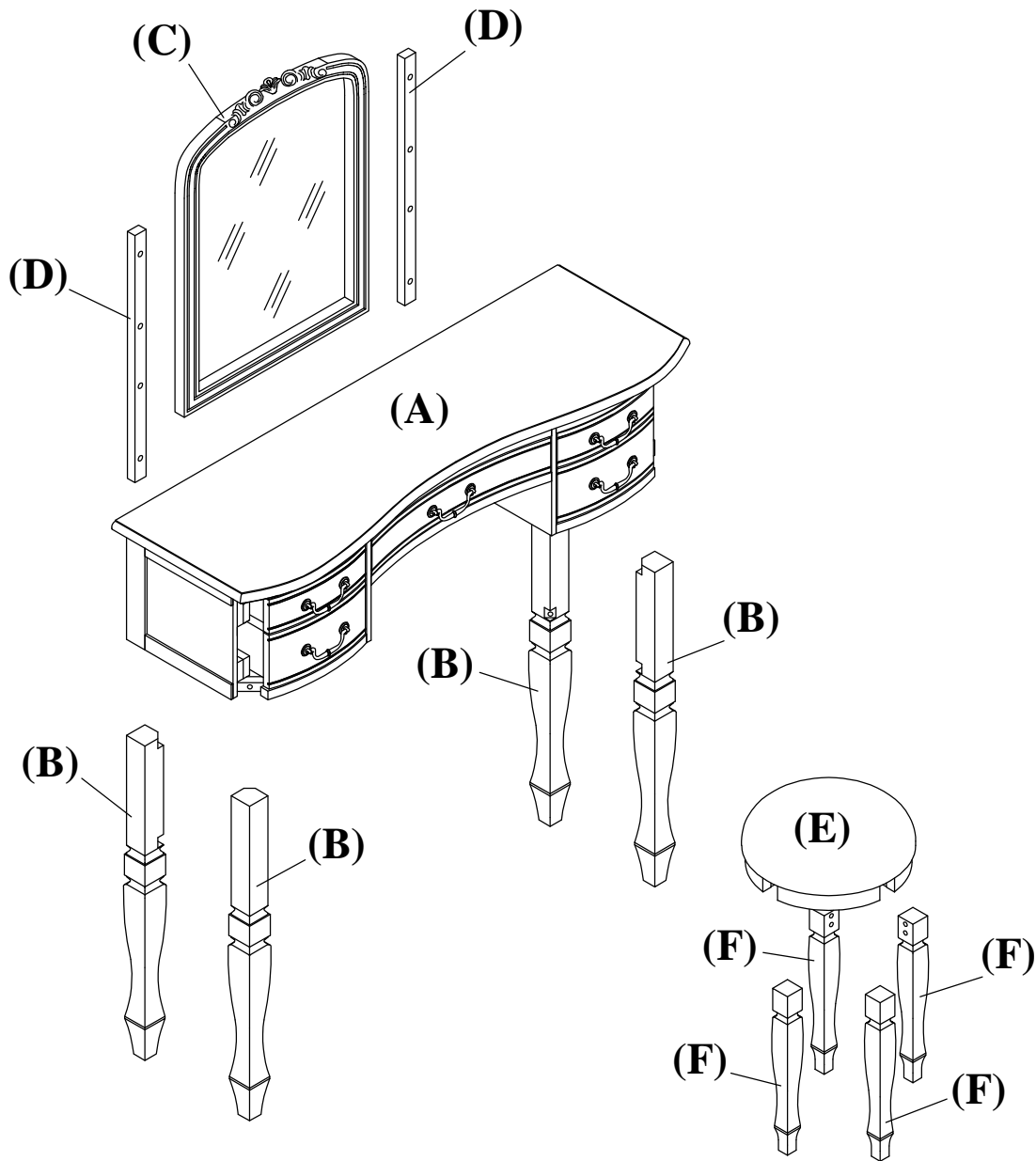

Notice:

1. **50% Tighten before fixing all screws, Allen wrench is recommended instead of an electric drill.**
2. **Place the item on a flat ground to adjust and make sure it remains stable. Tighten up all screws with tools gradually.**
3. **Tighten up all screws with tools gradually.**
4. **If the screws are not aligned with holes during assembly, please loosen all the other screws to 50% and continue the assembly process.**
5. **If the item is not stable, please loosen all the screws, adjust it on a flat ground and tighten up all screws again.**
6. **Note: If one or some screws are fully tightened during assembly, chances are the others will not be aligned with holes. In addition, all the holes are designed to be relatively larger to provide more space for the adjustment of the screws.**

PARTS LIST

A

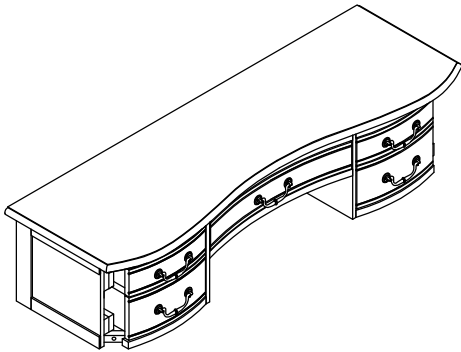

Table top (1 PC)

B

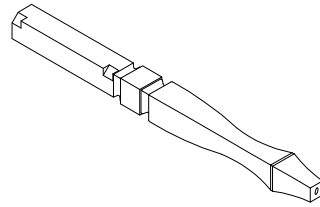
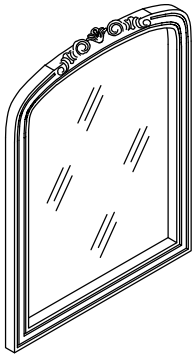

Table Legs (4 PCS)

C



Mirror (1 PC)

D

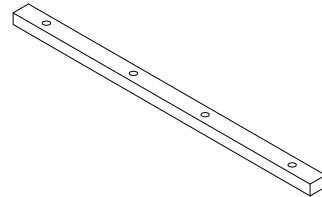

Support Mirror (2 PCS)

E

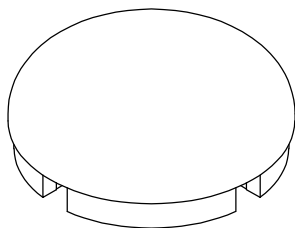



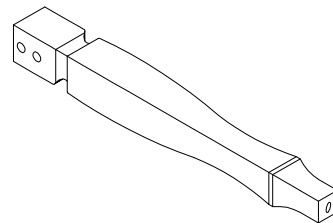

Chair with Cushion (1 PC)

F

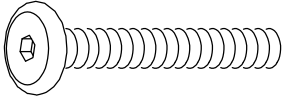

Chair Legs (4 PCS)

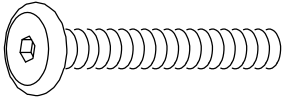
HARDWARE LIST

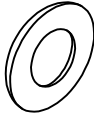
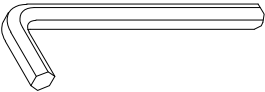
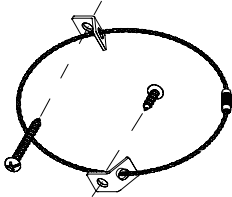
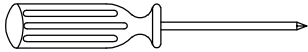
<p>1</p>  <p>Bolt 5/16" x 50mm (16 PCS)</p>	<p>2</p>  <p>Lock Washer 5/16" (16 PCS)</p>	<p>3</p>  <p>Flat Washer 5/16" (16 PCS)</p>
<p>4</p>  <p>Bolt 1/4" x 35mm (8 PCS)</p>	<p>5</p>  <p>Lock Washer 1/4" (8 PCS)</p>	<p>6</p>  <p>Flat Washer 1/4" (8 PCS)</p>
<p>7</p>  <p>Allen Key 4mm (1 PC)</p>	<p>8</p>  <p>Anti- Tip Restraint x 2 Set</p>	<p>9</p>  <p>Screw driver (not provided)</p>

CARTON CONTENT

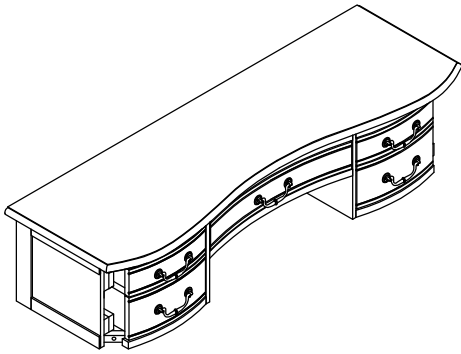

A x 1

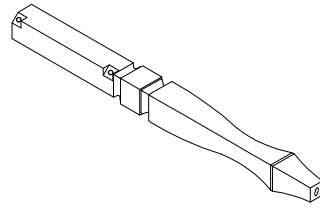

B x 4

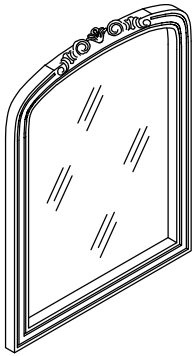

C x 1

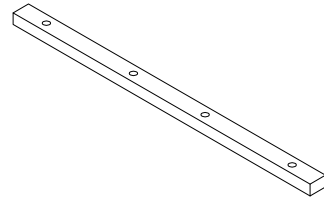

D x 2

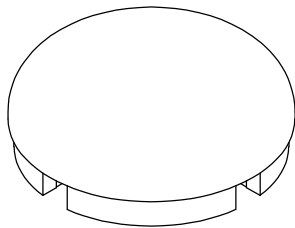



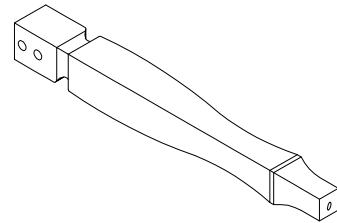

E x 1

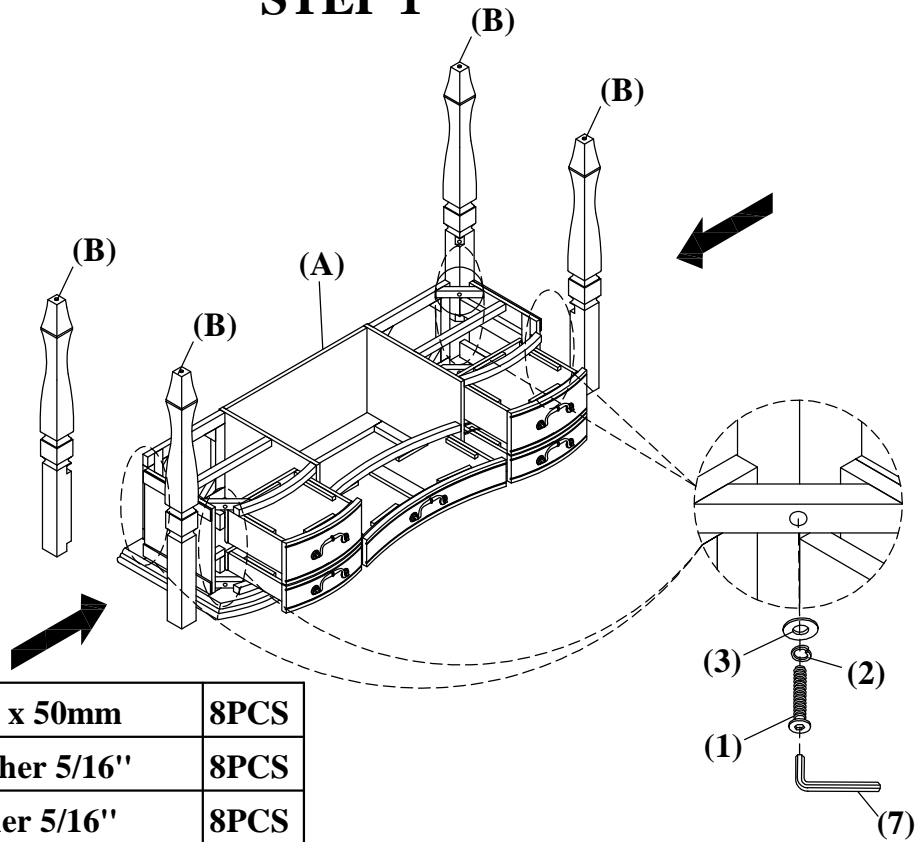

F x 4





STEP 1

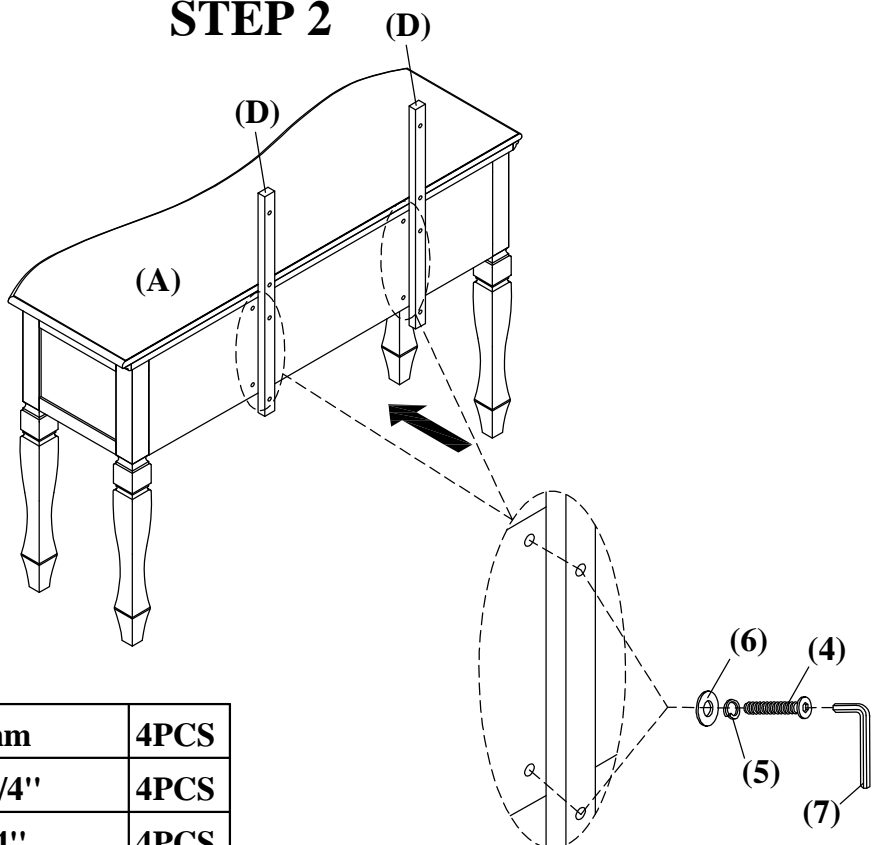

1		Bolt 5/16" x 50mm	8PCS
2		Lock Washer 5/16"	8PCS
3		Flat Washer 5/16"	8PCS
4		Allen Key 4mm	1PC

STEP 2



4		Bolt 1/4" x 35mm	4PCS
5		Lock Washer 1/4"	4PCS
6		Flat Washer 1/4"	4PCS
7		Allen Key 4mm	1PC

STEP 3

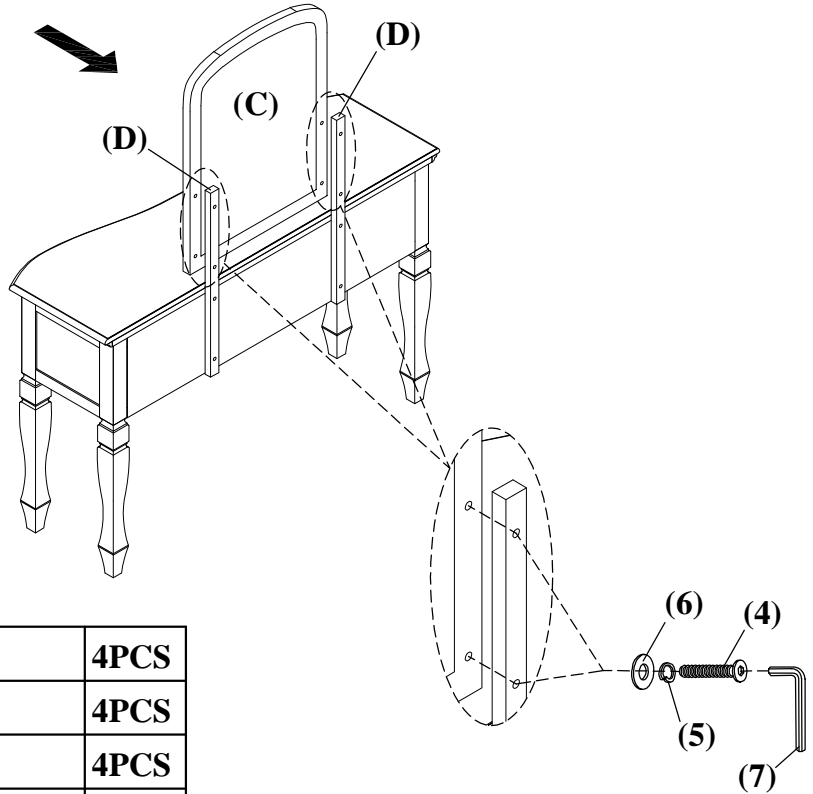

4		Bolt 1/4" x 35mm	4PCS
5		Lock Washer 1/4"	4PCS
6		Flat Washer 1/4"	4PCS
7		Allen Key 4mm	1PC

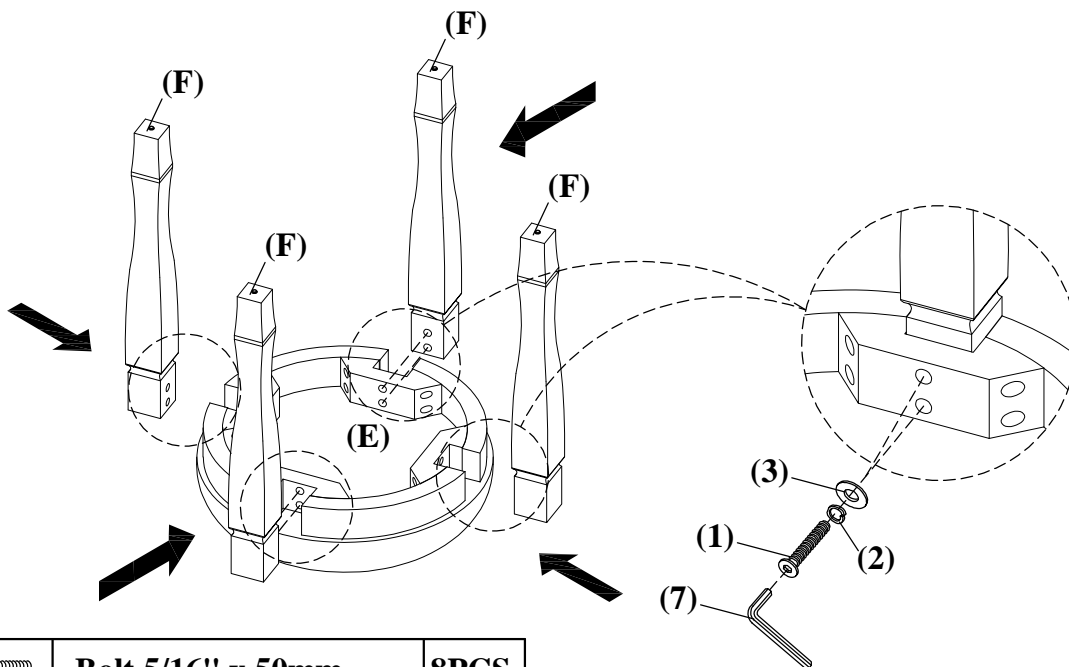

STEP 4



1		Bolt 5/16" x 50mm	8PCS
2		Lock Washer 5/16"	8PCS
3		Flat Washer 5/16"	8PCS
4		Allen Key 4mm	1PC

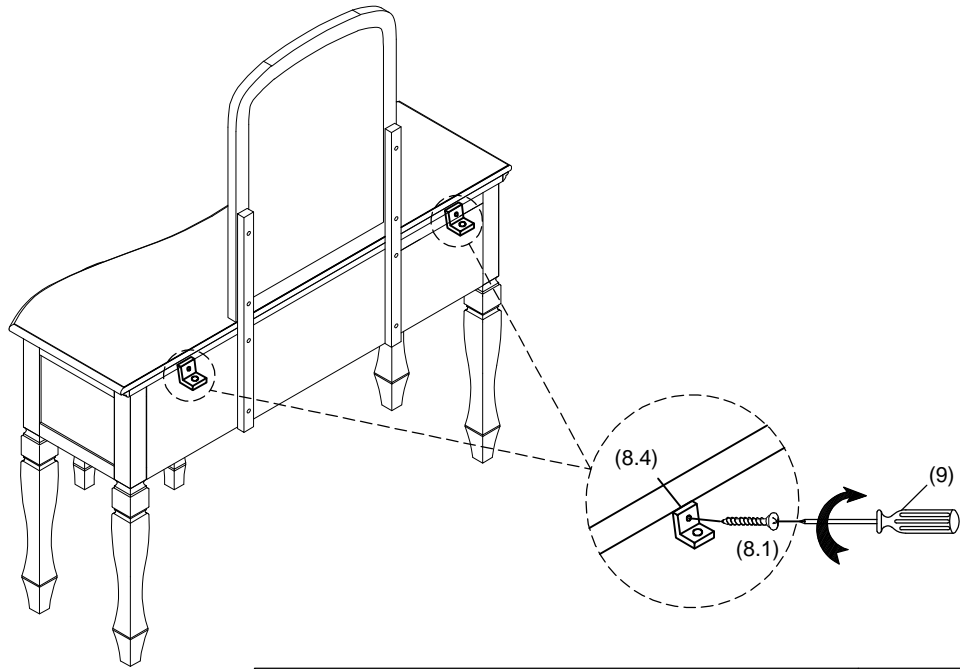

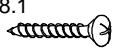
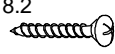
STEP 5

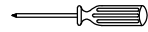

Anti-Tip Restraint x 2 set				9
8.1  16mm screw x1	8.2  50mm screw x1	8.3  Tie Strap x1	8.4  L Bracket x2	 Screw driver (not provided)

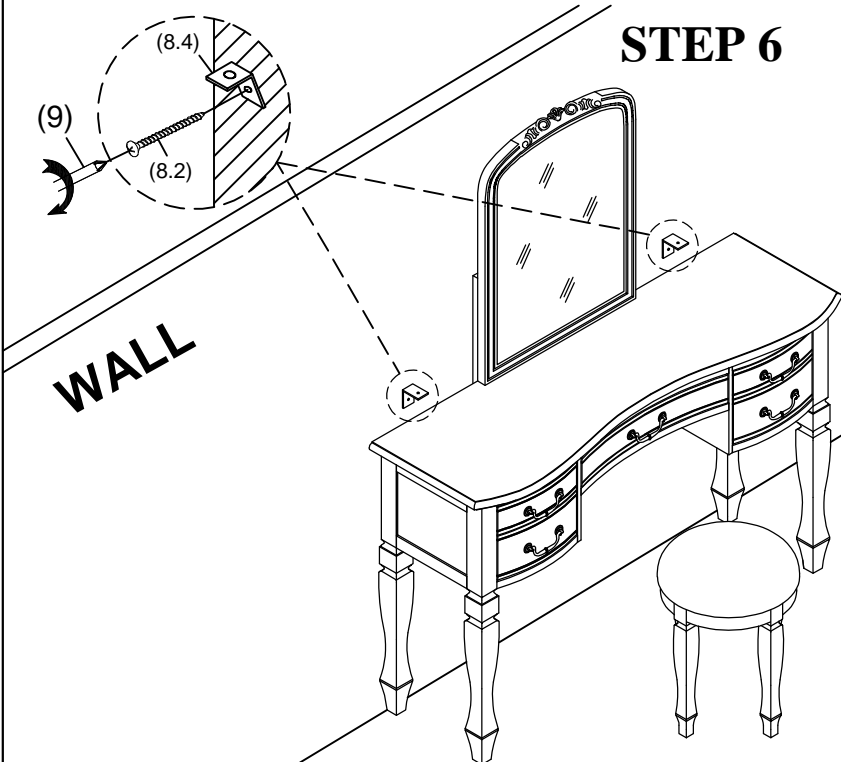
STEP 6

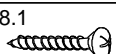
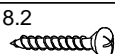

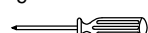
Anti-Tip Restraint x 2 set				9
8.1  16mm screw x1	8.2  50mm screw x1	8.3  Tie Strap x1	8.4  L Bracket x2	 Screw driver (not provided)

STEP 7

WALL

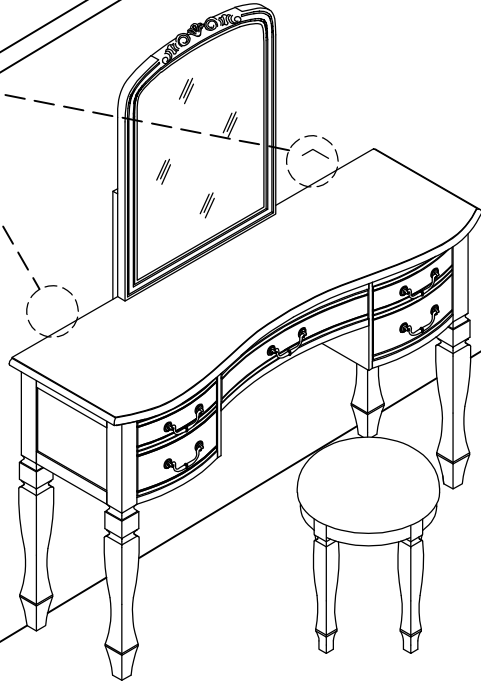
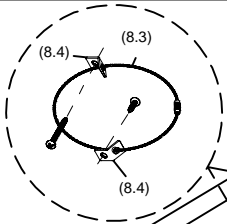

Anti-Tip Restraint x 2 set

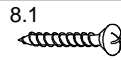

16mm screw x1

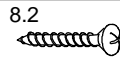

50mm screw x1



Tie Strap x1



L Bracket x2

9

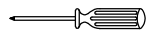

Screw driver
(not provided)

FINISH

